

THE SCIENCE  OF SURVIVAL



# Pathfinder™ Pro

SEARCH AND RESCUE TRANSPONDER

USER MANUAL



Copyright © 2024 by ACR Electronics, Inc.

All contents of this manual are the intellectual property of ACR Electronics, Inc.

This includes but is not limited to text, diagrams, illustrations, and any other materials contained herein. No part of this manual may be altered and further produced in any form, electronic or mechanical, without the prior written permission of ACR Electronics, Inc.





For permission requests or inquiries, please contact [service@acrartex.com](mailto:service@acrartex.com)

ACR Electronics, Inc. reserves the right to change or update the contents of this manual without prior notice. While every effort has been made to ensure the accuracy of the information provided, ACR Electronics, Inc. assumes no responsibility for errors or omissions.

Pathfinder™ is a registered trademark of ACR Electronics, Inc.

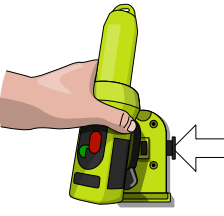
## **IN CASE OF EMERGENCY**

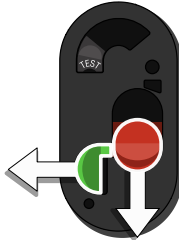

Use only in situations of grave and imminent danger

<p>Press release latch and remove from bracket.</p> 	<p>Break off clear protective cover over the green and red switches.</p> 	<p>Holding the green switch to the left, push the red switch down and hold.</p> 	<p>Whilst holding the red switch down, release the green switch to lock in active position.</p> 
--	--	---	---

Use the lanyard to attach the Pathfinder Pro SART to the roof of the liferaft.

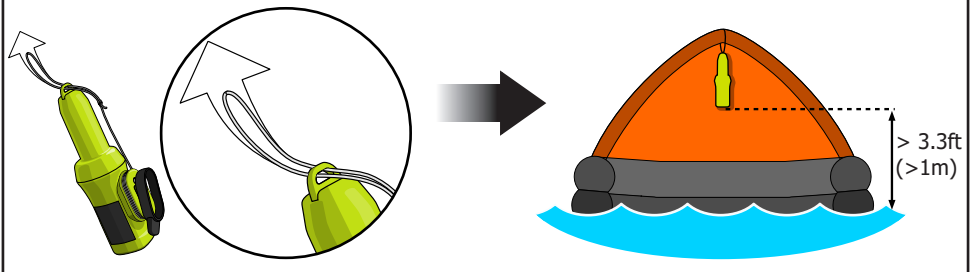
**NOTE:** Thread the lanyard through the lanyard attachment point before tying to the liferaft canopy in order to maintain an upright position.



-  **The Pathfinder Pro SART should be mounted at least 1m (3.3ft) above sea level for maximum effectiveness during activation.**
-  **The Pathfinder Pro SART should be tethered to the life raft using the lanyard to avoid being lost overboard.**

**NOTE:** Refer to section 4.3 for deployment instructions.

**NOTE:** Refer to section 4.4 for deactivation instructions.



# PATHFINDER PRO USER MANUAL

---

## CONTENTS

<b>1.</b>	<b>GENERAL</b>	<b>5</b>
	1.1 Exposure to RF Electromagnetic Energy	5
	1.2 Warnings	5
	1.3 Pathfinder Pro SART Contents	5
<b>2.</b>	<b>PATHFINDER PRO SART OVERVIEW</b>	<b>6</b>
<b>3.</b>	<b>INSTALLATION</b>	<b>7</b>
	3.1 Bracket Installation	7
	3.2 Battery Installation	8
<b>4.</b>	<b>OPERATION</b>	<b>8</b>
	4.1 Activation	8
	4.2 Optical indications on activation	9
	4.3 Deployment	9
	4.4 Deactivation	10
<b>5.</b>	<b>TESTING</b>	<b>10</b>
	5.1 Function Test	10
<b>6.</b>	<b>BATTERIES</b>	<b>11</b>
	6.1 Battery Replacement	12
<b>7.</b>	<b>APPENDIX</b>	<b>13</b>
	7.1 Maintenance and Troubleshooting	13
	7.2 Battery Safety Information	13
	7.3 Handling and Storage	13
	7.4 Transportation	14
	7.5 Accessories	14
	7.6 Specifications	14
	7.7 Approvals	15
	7.8 Limited Warranty	15

## 1. GENERAL

### 1.1 Exposure to RF Electromagnetic Energy

This product has been evaluated for compliance with the FCC RF exposure limits given in CFR 47 part 2.1093: Portable Devices.

### 1.2 Warnings

- Always operate the Pathfinder Pro SART with any part of the device at least 6cm (2.4in) away from your body**
- The Pathfinder Pro SART is designed for use in emergency only. Only operate it in situations of grave and imminent danger.**
- The Pathfinder Pro SART incorporates a protective tab over the operating controls to avoid accidental activation and indicate that the unit has been used.**
- After any period of operation, the battery should be replaced and the unit returned to your local service dealer for replacement of the protective tab.**
- Always replace the battery before the expiry date is exceeded to ensure full operating capacity in case of emergency.**
- Please ensure you follow local regulations before disposing of this item. Ensure the battery is removed from the unit before disposal.**

### 1.3 Pathfinder Pro SART Contents

1	4x Screws (for bracket)
2	Pathfinder Pro SART
3	Quick Start Guide
4	Hex Key (for battery)
5	SART Battery Module
6	Mounting Bracket

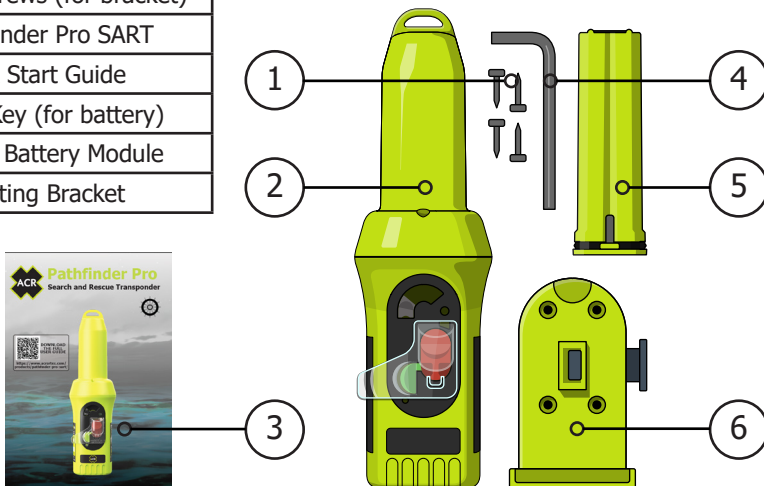



# PATHFINDER PRO USER MANUAL

## 2. PATHFINDER PRO SART OVERVIEW

1. Lanyard Attachment Point
2. Test Switch
3. Activation Switch
4. Clear Protective Cover
5. Indicator LED
6. Interlock Switch
7. Attachment Point for Optional Pole
8. Battery Module with Expiry Date



## 3. INSTALLATION

### 3.1 Bracket Installation

The Pathfinder Pro SART is supplied with a quick release mounting bracket. This bracket should be mounted on a suitable wall or bulkhead in a position where it can easily be retrieved in an emergency.

Although the Pathfinder Pro SART is rugged and waterproof, ACR Electronics recommends mounting the unit in a protected position whenever possible.



**Do not mount the Pathfinder Pro SART closer than 1 meter to any steering compass as this may affect the accuracy of the compass.**



**Keep the Pathfinder Pro SART away from any strong magnetic sources such as loudspeakers, compass compensation magnets, etc.**

Mark the location of the four screw holes onto the mounting position. Pre-drill the holes if required then screw the mounting bracket to the surface using the four No6 x 5/8" screws supplied.

The Pathfinder Pro SART simply clips onto the mounting bracket.

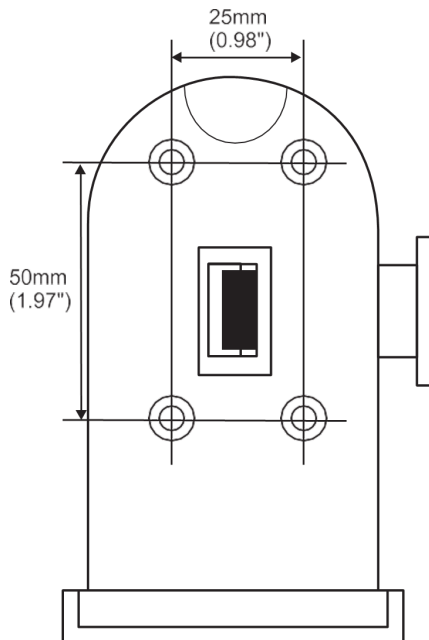



## 3.2 Battery Installation

The battery pack is retained by a single hex head screw using the 3mm hex key provided.

Insert the battery pack into the bottom of the Pathfinder Pro SART, ensuring that the rubber seal is correctly in position.

Tighten the screw until the battery is fully home within the Pathfinder Pro body, torque not exceeding 0.5Nm.

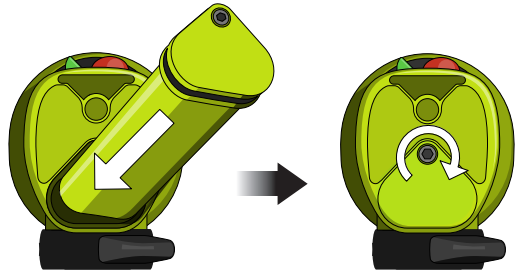

## 4. OPERATION

Ensure the Pathfinder Pro SART is fitted with an unused battery that is within the marked expiry date.

**⚠ A SART is not intended as a primary distress alerting device. At least one of the following should also be carried on-board your vessel to alert the authorities to your situation: an EPIRB; a DSC radio; an Inmarsat satellite terminal.**

Once the Pathfinder Pro SART is activated it will help guide the Search and Rescue authorities to your position.

### 4.1 Activation

**⚠ The Pathfinder Pro SART should only be activated if there is grave and imminent danger to the vessel and its crew.**

To activate the Pathfinder Pro SART, remove the unit from its mounting bracket.

Break off the clear protective cover over the green and red switches.

Holding the green switch to the left, push the red switch down and hold.

While holding the red switch down, release the green switch to lock the red switch in the active position.

**NOTE: See section 4.2 for optical indications on activation**

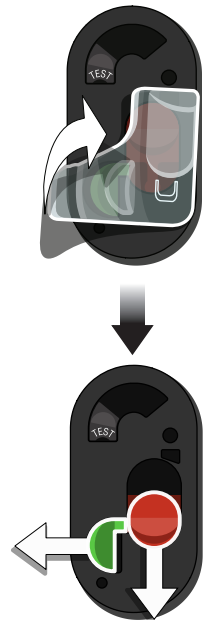



## 4.2 Optical indications on activation

During operation, the red LED next to the Test switch will flash once every 2-3 seconds to indicate the SART is operational:



When activated by a received radar pulse the red LED will start flashing rapidly:



## 4.3 Deployment



**The lanyard should be unwound and tied securely to the life raft to ensure the Pathfinder Pro SART is not lost overboard.**

For the best performance, it is important that the Pathfinder Pro SART is mounted as high as possible in the life raft.

Remove the rubber lanyard cover from the back of the Pathfinder Pro SART to reveal the lanyard stowed underneath. Use this lanyard to attach the Pathfinder Pro SART directly to the liferaft canopy or tie the lanyard around the inflatable tube supporting the canopy.

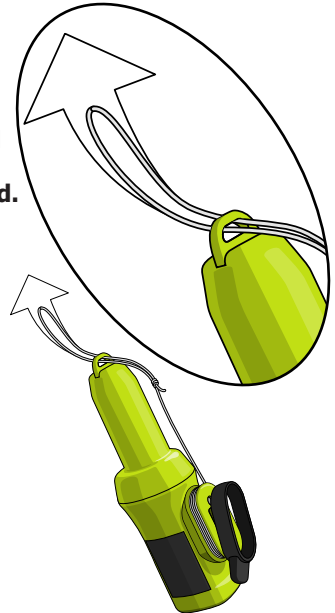

**NOTE: Thread the lanyard through the attachment point at the top of the SART. This will allow the SART to remain in an upright position when attached to the liferaft canopy from above.**

The Pathfinder Pro SART can be fitted with the optional telescopic pole which will keep the unit at a height of 3.3 feet (1m) above sea level.

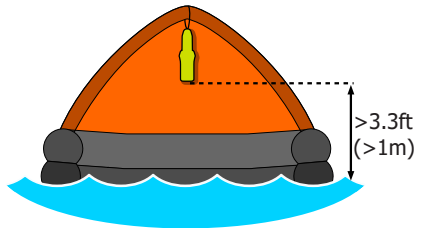

See the instructions supplied with the optional telescopic pole for correct attachment and use.





# PATHFINDER PRO USER MANUAL

## 4.4 Deactivation

If the Pathfinder Pro SART has been inadvertently activated, it can be turned off simply by reversing the activation process.

Holding the green switch to the left, push the red switch upwards to return to the off position.

Release the green switch.



**It is not possible for the user to replace the clear protective cover. Return the Pathfinder Pro SART to an ACR Electronics authorised service centre for replacement.**

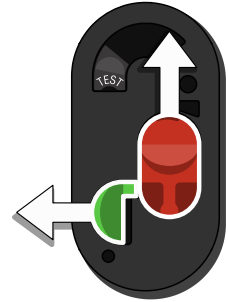

## 5. TESTING

### 5.1 Function Test



**This test should be carried out once per year.**

It is recommended that the Pathfinder Pro SART is tested once a year in conjunction with an X-band radar on a nearby vessel if possible. A full test should always be carried out as part of the annual service, with short inspections every two months.

Activate Test Mode by rotating the grey test switch clockwise and holding.

If there is radar activity in the area then the red LED will start to flash intermittently, indicating that the radar signals are being received.

The radar display of any vessels within radar detection range of your location will now be showing the return from the Pathfinder Pro SART.

Depending on the distance of the vessel to the Pathfinder Pro SART and the tuning of the radar, the display will vary between a set of concentric rings to a line of twelve blips in a straight line on a bearing between the vessel and the Pathfinder Pro SART.

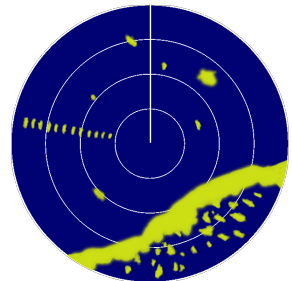
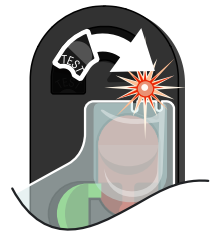

**Test Mode is the same as Activation Mode, so keep the test duration to a minimum to avoid falsely alerting other vessels that you may be in distress and minimise battery drain.**

## 6. BATTERIES

The Pathfinder Pro SART uses a Lithium Iron Disulfide battery pack to power the device. These batteries have a five year storage life before any significant reduction in capacity. Each battery is marked with an expiry date, which is located at the base of the unit.



**The battery should be replaced before the expiry date has passed to ensure reliable operation and full capacity in emergency situations.**



**Always use batteries manufactured by ACR Electronics. Failure to do so will invalidate the type approval and may mean the unit does not operate correctly in a distress situation.**



**Never dispose of batteries in a fire.**



**Never puncture or attempt to dismantle the battery.**



**Never attempt to charge the battery.**



**Extreme temperature caused by failure to observe the above warnings may cause the battery to explode or catch fire, which may result in injury or damage to surrounding personnel or property.**



**Dispose of used batteries in a responsible manner. National or local regulations on battery disposal may apply including restricting the disposal of batteries in domestic refuse.**

For the Product Safety Data Sheet and advice on battery transportation, please see the ACR Electronics website at [www.acrartex.com](http://www.acrartex.com).



# PATHFINDER PRO USER MANUAL

## 6.1 Battery Replacement

The battery may be changed by the user, although commercial vessels may be subject to local regulations relating to Shore Based Maintenance that prevent this.

Remove the Pathfinder Pro SART from its mounting bracket and turn it over. The battery pack is retained by a single hex head screw. Undo the screw using the 3mm hex key provided.

Remove the pack from the main body.

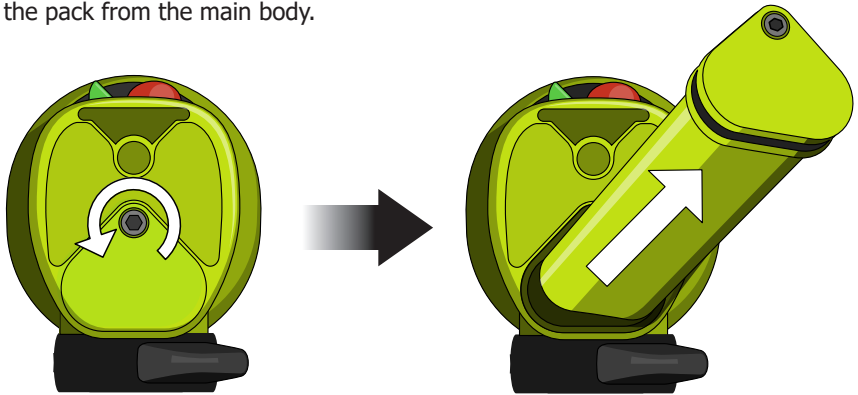

Insert new battery pack, ensuring that the rubber seal is correctly in position.



**Tighten the screw until the battery is fully home within the Pathfinder Pro SART body, torque not exceeding 0.5Nm.**



**Ensure that any maintenance records on-board are updated with the new battery expiry date.**



## 7. APPENDIX

### 7.1 Maintenance and Troubleshooting

The Pathfinder Pro SART should not need servicing during its lifetime, with the exception of changing the battery before the marked expiry date.

Regular cleaning, inspection and testing are advised - clean any grime or salt residue off the unit with a weak solution of detergent in warm water. Never use solvents as this may affect the structural integrity of the plastics used. Rinse well with fresh water after cleaning.

Inspect the unit for signs of case damage or cracks, check the labels are intact and the battery is within the expiry date. Make sure the optional telescopic pole (if provided) is still present and is free to extend.

Check for correct SART operation using the Test Mode (section 5). If the Pathfinder Pro SART appears to fail testing, contact a service representative at ACR Electronics.

### 7.2 Battery Safety Information

Manufacturer name: LB3S

Volts: 3.0V nominal

Approximate weight: 89grams

Chemical system:  $\text{LiFeS}_2$

Lithium weight/cell: 0.98g

Total lithium weight/battery: 1.96g

Designated for recharge: No

For information regarding the physical and chemical properties, the potential health and safety measures and the environmental effects of the battery used with this product, refer to the manufacturer's safety information documentation.

The safety information is available for download at [www.acrartex.com](http://www.acrartex.com)

### 7.3 Handling and Storage

This product should be stored in a cool and well-ventilated area. Elevated temperatures can result in a reduction of battery life. Locations that handle large quantities of lithium batteries must ensure the batteries are isolated from combustibles.

Avoid accidentally short-circuiting batteries. Prolonged short-circuiting can cause the battery temperature to rise and significantly reduce battery life.



## 7.4 Transportation

The (LB3S) SART battery module has been tested in accordance with subsection 38.3 of part III of the UN Manual of Tests and Criteria. Summary test reports are available from ACR Electronics on request.

This battery module should be transported by air in accordance with the IATA dangerous goods regulations: class 9, UN3090, proper name "Lithium metal batteries" and packed according to packing instruction 968 section Ib.

When supplied with equipment it is class 9, UN3091, proper name "Lithium metal batteries packed with equipment" and should be packed in accordance with packing instruction 969 section II.

## 7.5 Accessories

Replacement (LB3S) SART Lithium Battery .....	Part Number: 2920
Optional Telescopic Mounting Pole .....	Part Number: 2918

## 7.6 Specifications

### Transmitter

Frequency .....	9.2-9.5GHz
Output Power (EIRP) .....	>400mW
Number of sweeps per interrogation .....	12

### Battery

Type .....	Lithium Iron Disulfide (LiFeS <sub>2</sub> )
Operating life (standby/active) .....	96/12 hours at -20°C
Lithium Metal Weight (for air transport) .....	<2g per battery
Replacement interval .....	5 years

### Test Standards

Standards .....	IEC61097-1, IEC60945
-----------------	----------------------

### Environmental

IEC60945 Category .....	Portable
Temperature Range (operating) .....	-20°C to +55°C
Temperature Range (storage) .....	-30°C to +65°C
Waterproof .....	10 meters
Drop proof (on water) .....	20 meters
Compass safe distance .....	1 meter



# PATHFINDER PRO USER MANUAL

---

## 7.7 Approvals

The Pathfinder Pro SART is approved under the EU Marine Equipment Directive under MED/4.18 of the current implementing regulation. The Declaration of Conformity can be downloaded from [www.acrartex.com](http://www.acrartex.com).

The Pathfinder Pro SART is approved under the UK Marine Equipment Regulations, MSN 1874 as amended.

The Pathfinder Pro SART complies with the GMDSS provisions of part 80 of the FCC rules.

## 7.8 Limited Warranty

Your Pathfinder Pro SART is warranted against manufacturing defects in materials and workmanship for a period of two years from date of purchase. ACR Electronics will, at its discretion, repair or replace a faulty product free of charge, including return carriage costs to the owner.

For further assistance, please contact our Technical Service Department:  
Email: [support@acrartex.com](mailto:support@acrartex.com)

Accidental damage and misuse or non-approved modifications are not covered by this warranty. This warranty does not affect your statutory rights.

See <https://www.acrartex.com/products/pathfinder-pro-sart/> for further warranty information.

Dealer Stamp:



Date of Purchase:

The background of the entire page is a dark, atmospheric landscape. The top half shows a night sky filled with numerous small, bright stars. Below the sky, there are dark, silhouetted mountains or hills. In the foreground, a body of water reflects the light from the sky and the distant land, creating a shimmering, iridescent effect with shades of blue, green, and purple. The overall mood is mysterious and serene.

5757 Ravenswood Road  
Fort Lauderdale, Florida 33312  
United States of America

support@acrartex.com  
**www.ACRARTEX.com**